

COMPLETE PCB DIAGRAM - SCHEMA PLATINE PRINCIPALE EQUIPEE - SCHALTUNG LEITERPLATTE KPL - SCHEMA PIASTRA COMPLETA - ESQUEMA PLATINA EQUIPADA
 29" XF SAMSUNG TUBE NARROW NECK

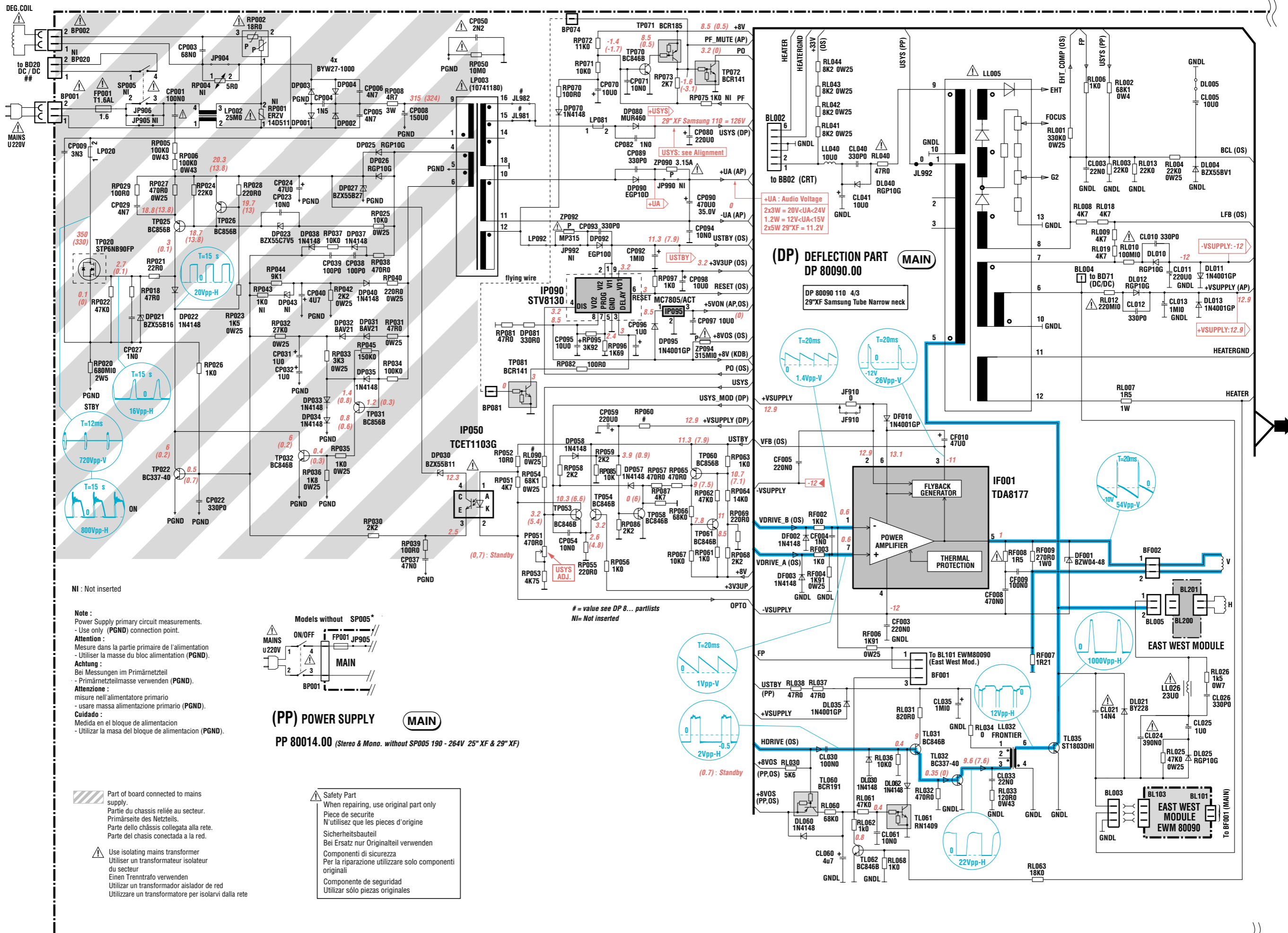

NI : Not inserted

Note :
 Power Supply primary circuit measurements.
 - Use only (PGND) connection point.
Attention :
 Mesure dans la partie primaire de l'alimentation
 - Utiliser la masse du bloc alimentation (PGND).
Achtung :
 Bei Messungen im Primärnetzteil
 - Primärnetzteilmasse verwenden (PGND).
Attenzione :
 misura nell'alimentatore primario
 - usare massa alimentazione primario (PGND).
Cuidado :
 Medida en el bloque de alimentacion
 - Utilizar la masa del bloque de alimentacion (PGND).

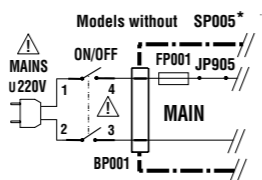

(PP) POWER SUPPLY **MAIN**
 PP 80014.00 (Stereo & Mono. without SP005 190 - 264V 25" XF & 29" XF)

Part of board connected to mains supply.
 Partie du chassis reliée au secteur.
 Primärseite des Netzteils.
 Parte dello chassis collegata alla rete.
 Parte del chasis conectada a la red.

Safety Part
 When repairing, use original part only
 Piece de securite
 N'utilisez que les pieces d'origine
 Sicherheitsbauteil
 Bei Ersatz nur Originalteil verwenden
 Componenti di sicurezza
 Per la riparazione utilizzare solo componenti originali
 Componente de seguridad
 Utilizar sólo piezas originales

COMPLETE PCB DIAGRAM - SCHEMA PLATINE PRINCIPALE EQUIPEE - SCHALTUNG LEITERPLATTE KPL - SCHEMA PIASTRA COMPLETA - ESQUEMA PLATINA EQUIPADA

TX807 CS - Stereo

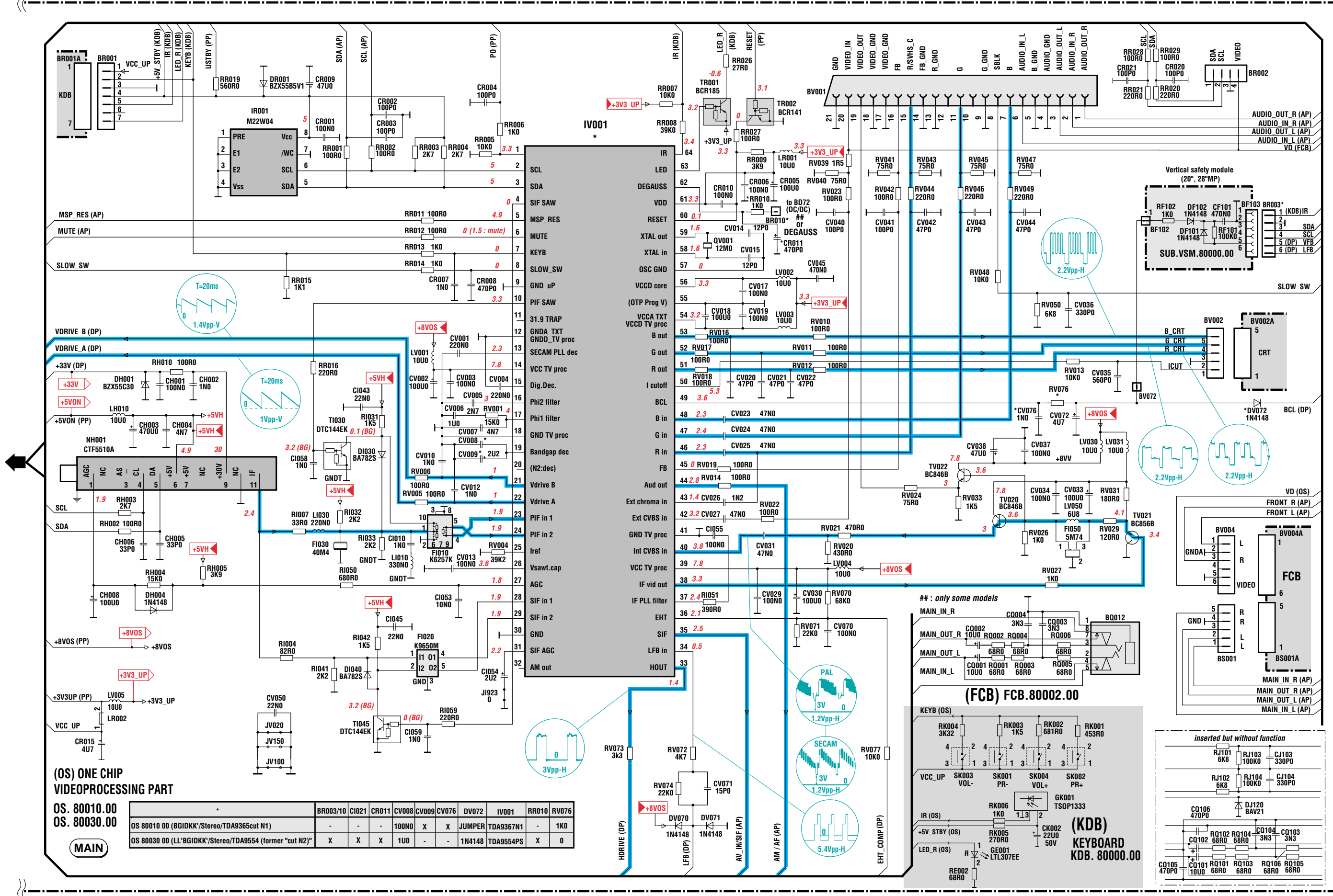

(OS) ONE CHIP
VIDEOPROCESSING PART

OS. 80010.00
OS. 80030.00

	BR003/10	CI021	CR011	CV008	CV009	CV076	DV072	IV001	RR010	RV076
OS 80010 00 (BGIDKK/Stereo/TDA9365cut N1)	-	-	-	100N0	X	X	JUMPER	TDA9367N1	-	1K0
OS 80030 00 (LL'BGIDKK/Stereo/TDA9554 (former "cut N2")	X	X	X	1U0	-	-	1N4148	TDA9554PS	X	0

MAIN

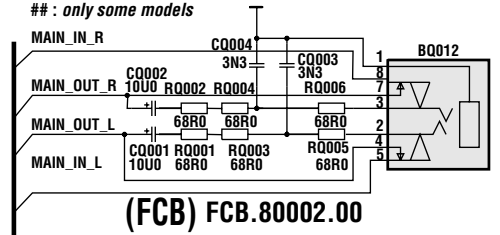

(FCB) FCB.80002.00

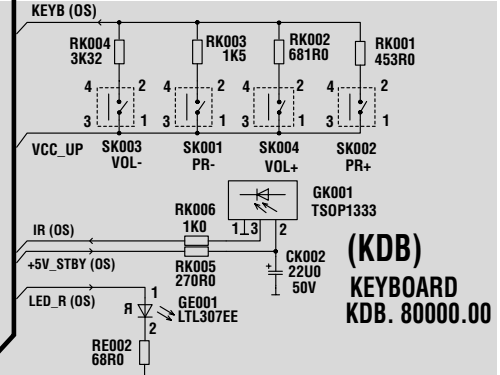

(KDB)
KEYBOARD
KDB. 80000.00

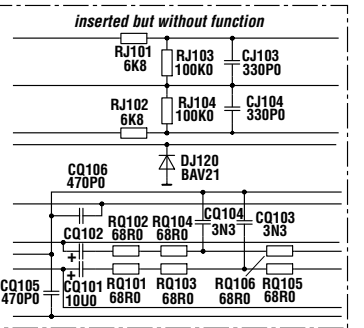
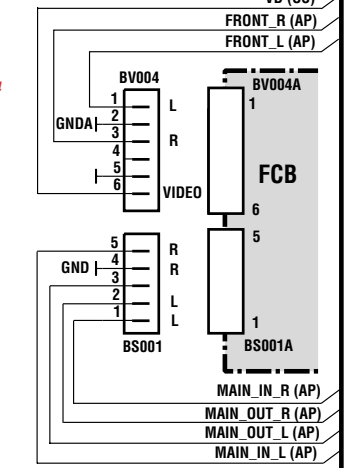

COMPLETE PCB DIAGRAM - SCHEMA PLATINE PRINCIPALE EQUIPEE - SCHALTUNG LEITERPLATTE KPL - SCHEMA PIASTRA COMPLETA - ESQUEMA PLATINA EQUIPADA
 STEREO AUDIO PART - TX807 CS

